

ROYAL AIRCRAFT ESTABLISHMENT, FARNBOROUGH

GERMAN GROUND RADAR EQUIPMENT

Preliminary Investigation of Display
Unit OSZ.62 of the FUSE 62.
(Wurzburg 39TA)

by

J.B. Supper
T.C. Mitchell

R.A.E. Ref : S.4761/126

SUMMARY

A Display Unit Type OSZ.62 has been reconstructed from captured equipment which was intentionally damaged by the enemy. A preliminary analysis has been undertaken with a view to promulgating the essential information in the shortest possible time. Comments and criticism on the function of the various circuits employed are offered and a list of items not properly examined or understood at present is included. This list will form a basis of a fuller investigation which will be undertaken later, the results of which will be included in a final report.

Contents

1. Introduction
2. Description of OSZ.62
3. The I.F. Output Unit (Endstufe)
4. The Master Oscillator (Tone-Generator)
5. The Time-base Generator
6. The Range Presentation Unit
7. Critical Notes and Comments
8. List of Items Requiring Fuller Investigation.
9. Relevant Technical Data Provided by Enemy Literature
10. Conclusions
11. Further work planned or in progress
12. References
13. List of Plates and Drawings

1. Introduction

This investigation was undertaken at the request of Air Ministry Intelligence (A.D.I.Sc.). Considerable technical information has been supplied by them including captured descriptive literature and prisoner of war reports. The materials available were three damaged units captured in Tunisia, two of which were very badly damaged. Fortunately, the damage to each unit was confined to different parts and, with the exception of one resistor and a paxolin panel, it was possible to reconstruct the unit completely with the original components.

The captured literature consisted of a descriptive manual (D.(Air)T.4500) and a fault finding manual (L.DV.g.704/6c), each complete with circuit diagrams and a nearly complete list of component parts. Some difficulty was experienced with the translation of the L.DV.g.704/6c, since much of it is in idiom and further ambiguities arise from the many inconsistencies and discrepancies in corresponding diagrams of the two manuals. The damaged instruments themselves, in-so-far-as the wiring could be traced, provided no further assistance in this direction; agreeing with one diagram in some respects and with the second in others. Moreover, from the evidence available, it is certain that the OSZ.62 has been subjected to several, and probably very hurried, modifications which,

Unclassified & not
as indicated within.
C.R.B. 17/1/1955.

Unclassified
~~Secret~~
T.N. No. Rad.178

judging by the way they have been carried out, were performed by personnel with little or no technical ability.

In consequence of this, no guarantee can be given that the reconstructed model is identical with an original in all respects, but it may safely be assumed that the underlying principles both in function and construction can be fully recognised.

It is pertinent to state that the OSZ.62 is probably now no longer in production as it seems to have been largely replaced by the ANG.62 and the EAG.62 which together form the display of the 39TD equipment. However, there are many points of similarity in the two displays and an understanding of the earlier model should provide a useful background when the examination of the later display is undertaken. (See para.11.)

2. Description of the OSZ.62

The display unit contains four distinct units :-

- (a) The I.F. output unit, consisting of a single 6.5 Mc amplifier stage followed by a full-wave demodulator and a single video stage.
- (b) The master oscillator generating tone for the pulse recurrence frequency.
- (c) The time base generator.
- (d) The range presentation apparatus, which includes a special cathode-ray tube.

Three external views of the apparatus are shown in figs.1, 2 and 3. Figure 1 gives a front view of the assembly with the mounting bracket and rubber (shock) supports clearly seen on the left. The face of the C.R. tube is protected both from light and weather by a cylindrical hood, it being remembered that this instrument is designed for direct exposure to weather. Three controls are provided on the front of the instrument, below the C.R.T. The left-hand control is pre-set and shifts the position of the received echoes with respect to the scale (Nullpunkt), the centre knob provides an adjustment for brightness (Helligkeit) and the right hand control is a switch which has four positions and provides the following facilities :-

- (a) P.R.F. of a few cycles under 3.75 kc.)
- (b) P.R.F. of 3.75 kc.) (Measure)
- (c) P.R.F. of a few cycles above 3.75 kc.)
- (d) P.R.F. of 5.2 kc. (Interrogate)

These frequencies are approximate.

This switch (Messen/Abfragen) therefore allows choice of three p.r.f.s which are within a few cycles of one another, with the object of clearing interference from an adjacent FUSE 62. The fourth position is used for I.F.F.

A side view is shown in figure 2 with the small flap open showing the housing of the I.F. output unit (Endstufe) and in figure 3 the large flap is shown lowered exposing the master oscillator and time-base generator. Figure 4 gives a rear view of the assembly removed from its case and the bank of metal rectifiers which provide the 4.2 KV supply to the C.R.T. can be clearly seen.

The assembly and chassis is of very rigid construction and the junctions of the members are spot welded. Light alloy material is used throughout and liberal use is made of unit component construction, an interesting example of which is shown in Figures 5 and 6. No ventilation is provided in the assembly housing, presumably because of the requirements of exposure to weather, and as a result the equipment runs rather warm. However, this does not appear to have had an adverse effect on it which is all the more remarkable when it is remembered that the equipment was in use in North Africa. The OSZ.62 is connected to the main equipment by a moulded rubber cable which can be seen in Figures 1, 2 and 3. All the internal wires are in one plane and can therefore be easily traced through the cable. This ribbon type of cable allows flat plugs to be used and therefore occupies much less space than the circular cross-section cable and plug which is standard in this country. Apart from this and the saving of space in storing large quantities, no special advantage can be seen in its use.

3. The I.F. Output Unit (Endstufe)

It is considered desirable not to include a technical description of the unit in this report. The "Endstufe" is properly part of the I.F. amplifier and will be considered together with that unit under a separate technical note (see para.11). Accordingly, the remainder of this report will be confined to a description of the master oscillator, time base generator and the G.R.T. circuits.

4. The Master Oscillator (Tone-Generator)

An exact replica of the enemy circuit, as captured, is given in Diagram 9154/B. and the Tone-generator is identified as valve R04, R05 and R06, shown in the upper left-hand screened compartment. A re-arrangement of this into a more familiar form is given in Diagram No. 9143/B. and it will be noted that some small differences exist between this and the enemy diagram. This is assumed to be the result of modification as the circuit of Diagram 9143/B represents the actual arrangement found to exist in the captured equipments.

The tone-generator consists of a two valve oscillator (R04 and R05) and a buffer amplifier (R06). The output of R05 is fed back in correct phase to the grid of R04 via a thermal bridge circuit, the function of which is to stabilize the oscillator in amplitude. The thermal arm of this bridge circuit consists of a German Osram lamp of the "flash-lamp" variety rated at 6 v, 0.04A. and the complementary arm is provided by a series tuned circuit which controls the frequency of the oscillator.

The remaining two arms each consist of a double wound (non-inductive) wire resistance which differ from each other in resistance by a few ohms to produce the slight unbalance necessary with this type of circuit (See Ref.2).

It is interesting to note that the oscillator is stabilized primarily in amplitude. This is necessary because of the high degree of freedom from distortion required by the circular time base used in this equipment. A distortion factor meter not being readily available, measurement of departure from pure sinusoidal form was not undertaken, however, the human eye can usually detect in a sine wave distortion factors down to 5% and a number of observers have agreed that the harmonic content in the sinusoidal output appears to be less than this.

The first valve of the tone-generator (R04) operates with 10 v. on its anode and 65 v. on its screen. This is an unusual operating condition the reason for which is not certain, but, the most plausible explanation is that the bridge stabilizer employed provides only a very small drive

Secret

T.N. No. Rad:178

and in consequence of this a high slope valve is usually used. For reasons of standardisation (presumably) the enemy has used a low slope pentode (1.8 m.a./v.) in a circuit providing a reasonably high stage factor of some 200. The remaining two valves, R85 and R86 operate normally in class A, the latter being provided with negative feed-back which allows it to handle a large grid swing without distortion. This feed-back is of the parallel/series variety and so ensures that the valve operates with low output and high input impedances. The amount of feed-back is controlled by the potentiometer W.18 which is used for determining the diameter of the trace (Durchmesser in figure 3). All three valves are Telefunken RV.12P. 2000. a type well known in this country and a family of Ia/Eg₁ curves is given in Diagram No. 9279B.

The resonant element of the bridge is provided with three capacitance networks selected by the switch U.1. (Messen/Abfragen in figure 1.) The function of this switch has already been described in paragraph 2 of this report, but in addition, via Bu 2, (7) and (5), it operates a relay in the Impulse Generator IC.62, to reduce the width of the transmitted pulse when set to Interrogate. (Para.11). The precise reason for reducing the pulse width during interrogation is not known at present but presumably has something to do with the I.F.F. responder (F.U.G.25) carried in enemy aircraft, or possibly simply to prevent the mean power output of the transmitter reaching too high a level.

The output from the tone-generator is taken directly to the time-base generator and is also passed via plug BU.2. (2) to the impulse generator IC.62. This output wave form is also taken to plug BU.1 (9) for purposes of monitoring.

A series of waveforms in the tone generator is given in Diagram No. 9145/B.

5. The Time-base Generator

The time-base generator consists of a single high power general purpose valve (LS.50) driving two coils, the currents in which differ in phase by 90°.

In Diagram No. 9154.B it is identified as R81 in the top right hand screened compartment and the base of the valve can be clearly seen on the right of figure 3. A re-arrangement is given on the right of Diagram No. 9143/B.

Tone derived from the output transformer of the tone-generator is applied to the grid of R81 via the variable phase shifting circuit of C1, W1, 2 and 3 and W.19. The latter is a variable resistance and allows the phase of the wave form applied to the time-base generator to be retarded by a maximum of 20° with respect to that applied to the Impulse Generator via BU.2 (2). This phase retarding network is designed to give a minimum change of amplitude with change of phase and for a shift of 20° the amplitude is reduced by not more than 5%. The variable resistance W.19 is identified as the pre-set "Nullpunkt" control in Figure 1 and reference has already been made to its functions in paragraph 2.

The display unit employs a circular time base (Figure 7) which is produced magnetically by four coils arranged 90° apart round the neck of the tube. Each pair 180° apart is connected in series thus forming two "push-pull" magnetic deflection systems at 90° to each other. These coils are shown single ended in Diagram 9143/B. and marked C.R.T. (L) and C.R.T. (K).

To produce a circular trace it is necessary that the current in the K. coils shall differ in phase by 90° with reference to the current in the L. coils. The method adopted by the enemy for achieving this is of interest and will therefore be considered in some detail. A simplified version of the phasing network for producing the circular trace together with the relevant vector diagram is given in Diagram No. 9183.B. From this it will be seen that each coil assembly forms part of one of two parallel circuits connected across the anode load D.1. Consider first the branch containing the L. coils. These coils have a total inductance of 39 mH and a resistance of 77 ohms and are in shunt with a $0.034 \mu\text{F}$ condenser. This network resonates at 4.4 kc/s. so that at a p.r.f. of 3.75 kc/s they are working close to, but below, resonance. The resulting impedance is inductive and the current I_2 will accordingly lag on the applied voltage E by a large angle. Since the Q of the coils is high the current I_L through them will lag by very nearly 90° on the applied voltage E. All the circuit elements in this branch have fixed values and so the vector relationship of E, I_2 and I_L are constant.

Next consider the branch containing the K deflection coils. These again are operated close to resonance ($f_0 = 4.2$ kc/s. optimum form setting) but in this case the parallel capacitance is capable of variation between 15 pf and 4,500 pf. In addition a series capacitance is included (C.7 & 8) which is also capable of variation over a small range (13 pf and 900 pf). Since the network C.9 12, and K operate slightly below resonance the resulting dynamic impedance will be inductive, but the resulting positive reactance is smaller in magnitude than the negative reactance of C.7 and 8 and in consequence of this the current I_1 leads the applied voltage E.

The remaining relationships are obvious from the vector diagram from which it will be seen that :-

- (a) The currents through each set of coils (I_3 and I_L) are slightly more than 90° apart. The effect of the resistance W.11 which for the sake of simplicity has here been neglected, will modify the diagram slightly; resulting in the vectors I_1 and E_1 , E_2 and I_3 all being retarded in phase by a very small angle. The vector I_L will of course remain unchanged and I_3 and I_L will be in exact 90° phase relationship.
- (b) The currents through each coil I_3 and I_L are not equal in amplitude. The reason for this is that the K coil assembly is further from the neck of the tube than is the L coil assembly. Consequently for equal magnetic fields the former must carry a larger current.
- (c) The currents through the coils are considerably larger than the total current drawn from the valve. This is due to the operation of the coils near resonance and results in a considerable saving in space and equipment. However, the circuits will not function satisfactorily with much departure from the frequency for which they are designed and this restricts the available range of p.r.f. for clearing interference (para.2). Moreover, where a large change in p.r.f. is necessary, as for instance when interrogating for I.F.F. (para.2), a complete collapse of the circular trace has to be tolerated and during the establishment of identity no Radar information can be available.

The component values shown on the network in diagram 9183/B were obtained by setting the equipment to give the best circular trace, and then measuring the values of C.7 and C.12. These two variable condensers will, of course, control the shape of the trace. The chief effect of varying C.7 is to advance or retard I_1 , and hence E_2 and I_3 with respect to E and I_L . It therefore might be termed the phase control. On the other hand C.12 has most effect on the current through the K coils, since it determines the resonant frequency of its network. This then might be regarded as the amplitude control. Both condensers are mounted on the side panel under the large flap. They are each labelled "FORM" and can be clearly seen in figure 3.

Referring again to diagram 9143/B each phasing network will be noted to form the balance arm of a d.c. bridge. These provide the shift circuits and are controlled by the potentiometers W.25 and W.28, which are mounted above the tone-generator and each marked "VERSCHIEBUNG" (Figure 3). The low impedance d.c. circuits are prevented from affecting the high impedance phasing circuits by the large iron cored chokes, D.2 and D.3.

High tension is supplied from an external power unit to the time-base generator and tone-generator via plug BU2 (4), and is relayed back to the I.F. amplifier via BU4 (7). A monitoring H.T. position is provided by BU1 (7).

6. The Range Presentation Unit

This unit (Diagram No. 9144/B) consists of the C.R. tube, the deflection coils and mountings, and a high voltage power supply.

The tube itself is labelled "L.B.13/40" and is specially designed for polar co-ordinate working. It is provided with conical deflection plates to ensure constant deflection sensitivity at all parts of the trace and is probably a specialized development of a polar co-ordinate tube designed by Von Ardenne in 1936 (See ref.3).

The accuracy of the circular figure produced by the tube can be judged from figure 7. The inner deflection cone is mounted inside the outer deflection cone by means of four supports and care has to be exercised when adjusting the circular figure to ensure that the obstruction to the electron beam produced by these supports has minimum visual effect. In figure 7 some defocussing can be seen at 22.5 km. on the calibrated scale and again at 3.5 km. The effect of the remaining two supports cannot be seen in the photograph. A detailed description of the L.B.13/40 tube is contained in a separate report. (See ref.4.)

All power supplies to the tube are provided for in the assembly and consist of a high voltage transformer U1, a metal rectifier and a simple smoothing system C.14, W.13, and C.15, providing a potential on load of 4.2 kv.

The metal rectifier is built up from a series of ten small rectifiers and in figure 4 can be clearly seen mounted over the transformer; the whole making a neat and compact H.T. pack.

A multi-potential divider across the H.T. supply provides the following potentials to the tube :-

	<u>Max.</u>	<u>Min.</u>	
Final Anode	0 V.	-	} Measured with respect to earth
Focus	-3.15 kv.	-2.8 kv.	
Cathode	-4.1 kv.	-	
Grid	-4.2 kv.	-4.1 kv.	

The divider also supplies a fault indicating neon (R82), not normally glowing, and a test point at BU 1 (5). Signal is fed to the conical deflection plates via plug BU 4 (1), and 180 V. 50 cycle regulated supply to the power pack via BU 2 (6) and (8). The function of BU 2 (9) and C.17 is not known but is further discussed in paragraph 7.

7. Critical Notes and Comments

7.1. The Tone-Generator

7.1.1. A comparison of diagrams 9154.B and 9143.B will show that in the latter there are ten separate condensers in the resonant arm of the bridge.

whereas in the former there are only seven. Since Diagram 9143.B represents the circuit as found, it is difficult to estimate what stage of development is represented by the enemy diagram. Normally, it would be assumed that the arrangement with the fewer components is the later version but other sections of the enemy diagram, notably the range presentation unit, make it almost certain that this is not the case. But overriding these considerations is the curious fact that so large a number of components is used for so simple a job. Clearly, the reason for standardisation cannot be advanced here since two of the values are 0.0181 $\mu\text{F.}$ and two others are 0.0138 $\mu\text{F.}$, none of which can be assumed to be standard. The situation is rendered even more strange by adding to this conglomeration of carefully chosen values two trimmers giving a wide range of capacitance.

7.1.2. As already mentioned in paragraph 4 the reason for reducing the pulse width during interrogation (operated by switch U1) has yet to be determined, and it is hoped, later, to conduct tests with the appropriate responder, FUG.25.

7.2. The Time-base Generator

7.2.1. The remarks contained in 7.1.1. above apply to some extent to the condenser elements in the K resonant circuit. The total fixed capacitance of 0.029 $\mu\text{F.}$ is built up from three apparently standard values, whereas in the L circuit a single condenser of non-standard value is used.

7.2.2. A second curious feature in the time-base generator is provided by the connections of the decoupling condensers C_2 , C_3 and C_4 . It will be noted that these are connected not to earth but to the H.T. line. The objection to this is apparent since all earth returns are made via a single condenser C.13. The standard arrangement of returning the decoupling condensers to earth would be more efficient and has been adopted in all other parts of the circuit. Inspection of the physical arrangements of the components in question leads to no conclusion; it would have been just as easy to connect to earth as to the H.T. line.

7.2.3. The valve R81 is shown on the enemy diagram as having four grids. The connection to all electrodes is shown to be external but there is no evidence as to the existence of G.4 either on the valve itself or on captured enemy valve base diagrams. According to these the valve is a normal pentode.

7.3. The Range Presentation Unit.

As stated in paragraph 6 the purpose of C.17 and B \bar{u} 2 (9) is not known. Comparison of the enemy diagram (Diag. 9154.B) with the circuit as found (Diag. 9144.B) brings to light a major difference in the connections to the grid and deflection cones of the C.R.T. In the former it will be noted that the inner deflection cone is connected to terminal 9 on plug B \bar{u} 2 by means of a screened cable. A resistance W.16 is connected from the grid of the C.R.T., via C.17, to the outer sheath of this screened cable which, in turn, is connected to earth via the resistance W.21. This is somewhat pointless, but the arrangement becomes even more so in the light of the three following facts.

- (a) The resistance W.21 is carefully shorted out.
- (b) The connection between W.16 and C.17 has been crossed out.
- (c) Terminal 9 on plug B \bar{u} 2, although stated on the enemy diagram to be used for "additional apparatus" is not connected to any external equipment.

A careful examination of all the damaged equipments disclosed that :-

- (a) The resistance W.21 was connected as in the enemy diagram and was, in fact, shorted out.
- (b) That one end of resistance W.16 was certainly connected to the grid of the tube but the other end was not connected to anything.
- (c) That the screened cable was not connected to the tube at all but was connected to one end of C.17, the other end of which was connected to the grid of the tube.

The arrangement therefore is as shown in Diagram 9144/B, and the screened cable in question and C.17 can be clearly seen in figure 4.

It is evident that the arrangement shown in the enemy diagram has been the subject of modification but whether this was the result of hurried development, or a major change in design, can only at this stage be surmised. The final arrangement suggests the possibility of some form of black-out or brightening pulse but since there is no connection between this and any other part of the equipment it is difficult to see what, after all, was the object of the modification. Furthermore, a prisoner of war questioned on this point stated that no marker pulses of any sort appeared on the trace.

7.4. General

It is of interest to consider the form and layout of the enemy diagram (Diagram 9154/B). This will be seen to be a cross between a schematic and a wiring diagram with a leaning towards the latter. All connecting wires are numbered and wires having identical function have the same numbers. For example, all wires at earth potential are numbered "0" and all wires distributing H.T. potential are numbered "16". The arrangement of the diagram follows closely, but not exactly, the physical arrangement of the unit itself. This type of diagram is very difficult to read and information of a functional nature is not readily obtained from it. All enemy circuit diagrams are in this form and the inference, therefore, is that the enemy technical personnel are not intended fully to grasp the working of the circuits, and that diagrams are provided solely for the purpose of tracing wires. This opinion is strengthened by the standard of literature supplied with the equipment.

One further point in connection with the enemy diagram calls for comment. It will be noticed that the components of the tone-generator are not annotated. The components in the equipment itself bear letters and numbers and these were found to overlap with markings in the time-base generator (See diagram 9143/B). It is standard German practice to annotate all components both in diagrams and on the components themselves. The exception in this case is presumably the best method the enemy could find to cope with some error in organization.

8. List of Items Requiring Fuller Investigation

- 8.1. Accurate measurement of frequency of the tone-generator in all four positions of switch U.1.
- 8.2. Measurement of harmonic content of sinusoidal output of the tone-generator.
- 8.3. Reason for reducing transmitter pulse width during interrogation.
- 8.4. Underlying reasons for the inclusion of B4 2 (9) and C.17 in the range presentation unit.

9. Relevant Technical Data Provided by Enemy Literature

The following information has been extracted from captured descriptive literature and is included here for general interest.

9.1. Range

Location of aircraft at a minimum of 25 km. (The display tube is calibrated up to 40 km. and it is presumed that this means the lowest acceptable maximum range is 25 km.)

9.2. Accuracy of Bearings

Azimuth (D.F. for max.)	$\pm 1^{\circ}$
Elevation (D.F. for max.)	$\pm 2^{\circ}$
I.F.F. Azimuth (D.F. for min.)	$\pm 2^{\circ}$

9.3. Accuracy of Range

About ± 150 metres for all distances.

9.4. Performance of Display Tube

Maximum spot diameter	2 m.m.
Near echoes operated at	2 cms. (deflection)

10. Conclusions

In drawing conclusions from the investigation described in this report, all remarks will be confined to the technical considerations underlying the design of the instrument. Comments on the operational features of the equipment will be deferred until field trials on the equipment as a whole are completed. (See para.11.)

With the exception of the time-base generator the circuit technique presents no new or novel features. The design is quite standard and, apart from the curiosities outlined in paragraph 7, is quite straight-forward.

As has been stated the time-base generator is an exception to this. The design of the phase-quadrature circuits is excellent and represents together with the special tube, a splendid example of the combination of high efficiency working, technical excellence and small size.

As regards the construction of the instrument, much can be learnt. The workmanship is excellent and so also are the layout, accessibility and compactness. The chief lesson to be learnt is probably one of component design. Most of the components are in general smaller than their British counter-parts and many have obviously been produced specially for the particular application. In some cases, for example, particular values of capacitances are built up of several standard ceramics and the whole included in one moulding, appearing as one condenser. A further good example of component construction is given by the bridge circuit of the tone-generator (figures 5 and 6).

Finally, it may be said that economy of materials e.g. rubber and light alloy, has not been allowed to interfere with the design. This is of special interest in view of the date of the design which was probably late 1938 or early 1939.

11. Further Work planned or in progress

The Impulse Generators I.G.62 and I.G.62A, the range presentation unit ANG.62, and the strobe unit EAG.62 will each be the subject of separate reports which will be issued later.

Work is in progress for the reconstruction of a complete German radar station and when this is done full operational trials will be undertaken. A report on the operational features of the equipment will be issued when these are complete.

12. References

1. T.R.E. Report S/R/25 "Final Technical Report on German R.D.F. Equipment Captured at Bruneval on 28.2.42".
2. Meacham. L.A. The Bridge Stabilized Oscillator. Bell System Technical Journal Volume XVII. No.4; October, 1938.
3. Von Ardenne. Manfred. A new Polar Co-ordinate Cathode-Ray Oscillograph, with extremely Linear Time Scale. Wireless Engineer, Volume 14, No.160. January, 1937.
4. Examination of German Cathode Ray Tube Type LB.13/40. R.A.E. Technical Note No.155.

13. List of Plates and DrawingsPlates

- | | | |
|--------|--|-----------------|
| Fig.1. | Display Unit Type O.S.Z.62 - Front view. | } Neg. No.50028 |
| " 2. | Display Unit Type O.S.Z.62 - Side view showing I.F. end Stage. | |
| " 3. | Display Unit Type O.S.Z.62 - Tone Generator and Time Base Generator | } Neg.No.50029 |
| " 4. | Display Unit Type O.S.Z.62 - Rear View with cover removed | |
| " 5. | Display Unit Type O.S.Z.62 - External View Bridge Stabiliser Unit | } Neg.No. 50030 |
| " 6. | Display Unit Type O.S.Z.62 - Internal View of Bridge Stabilizer Unit | |
| " 7. | Display Unit Type O.S.Z.62 - Time Base with artificial echoes | } Neg.No. 50031 |

Drawings

- | | | | | | |
|---------|-------|---|---|---|--|
| Diagram | 9143B | - | Display Unit O.S.Z. 62 | - | Time Base Circuits. |
| " | 9144B | - | " " " " | - | C.R.T. Supply Circuits. |
| " | 9145B | - | " " " " | - | Waveforms in Tone Generator. |
| " | 9146B | - | " " " " | - | Waveforms in Time Base Generator. |
| " | 9154B | - | Copy of Enemy Circuit Diagram of the Tone Generator and of the Range Measuring Equipment. | | |
| " | 9183B | - | Display Unit O.S.Z. 62 | - | Vector Diagram of Circle Phase Circuits. |
| " | 9279B | - | " " " " | - | Telefunken Valve R.V.12 P.2000. |

SECRET

Unclassified

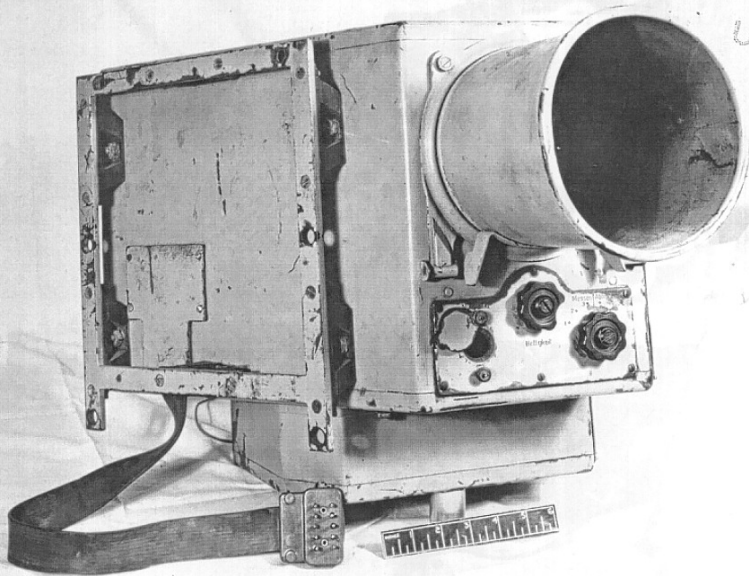

REAR VIEW

FRONT VIEW

FIG. 1.

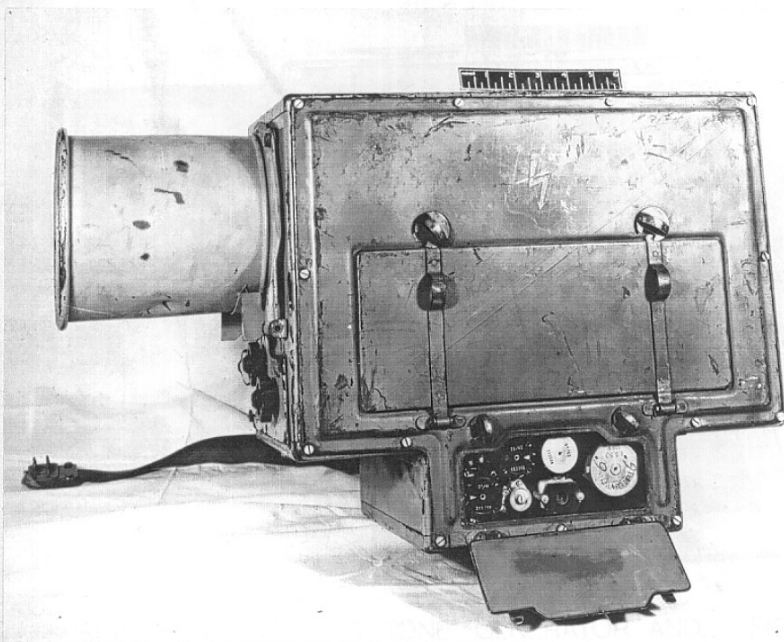

SIDE VIEW SHOWING I.F. END STAGE

FIG. 2.

GERMAN GROUND RADAR EQUIPT.
APPARATUS FUSE 62 (WÜRZBERG)
DISPLAY UNIT OSZ. 62.

Unclassified

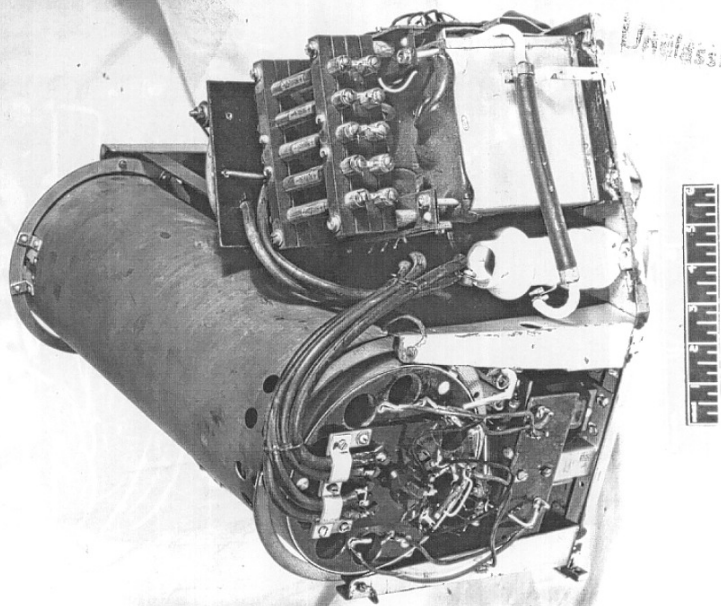

REAR VIEW WITH COVER REMOVED. FIG. 4.

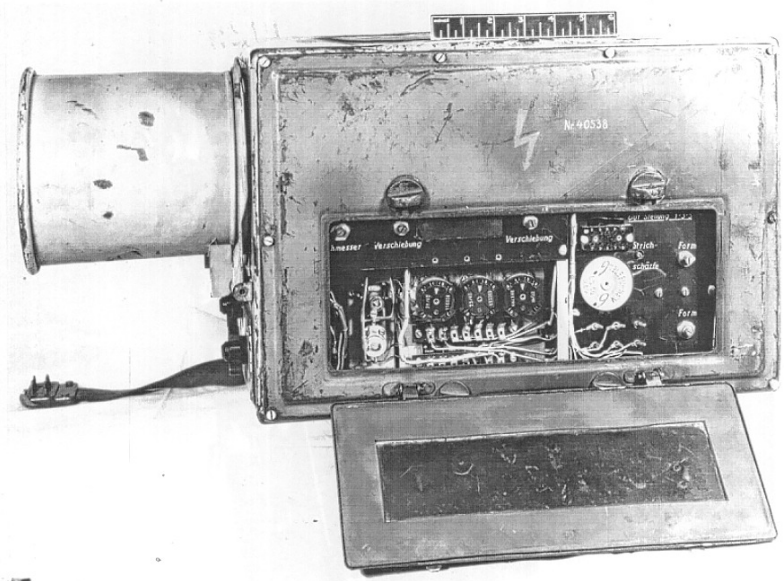

SIDE VIEW SHOWING TONE GENERATOR AND TIME BASE GENERATOR. FIG. 3.

GERMAN GROUND RADAR EQUIPT.
APPARATUS FUSE 62 (WÜRZBERG)
DISPLAY UNIT O.S.Z. 62.

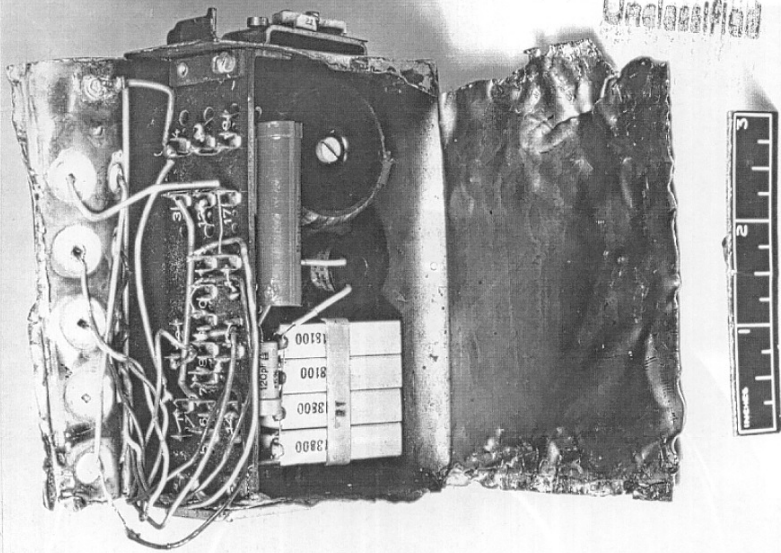

INTERNAL VIEW OF BRIDGE STABILISER UNIT FIG.6.

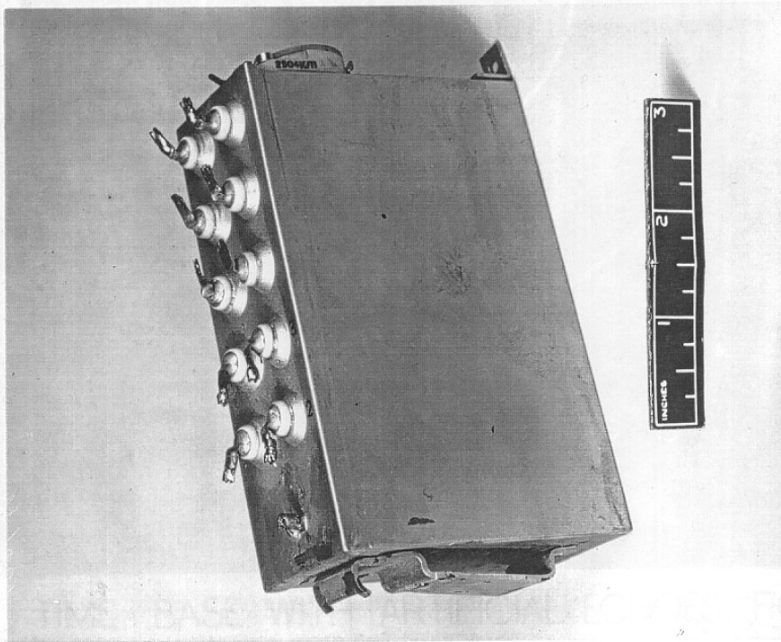

EXTERNAL VIEW OF BRIDGE STABILISER UNIT FIG.5.

GERMAN GROUND RADAR EQUIPT.
 APPARATUS FUSE 62 (WÜRZBERG)
 DISPLAY UNIT OSZ. 62.

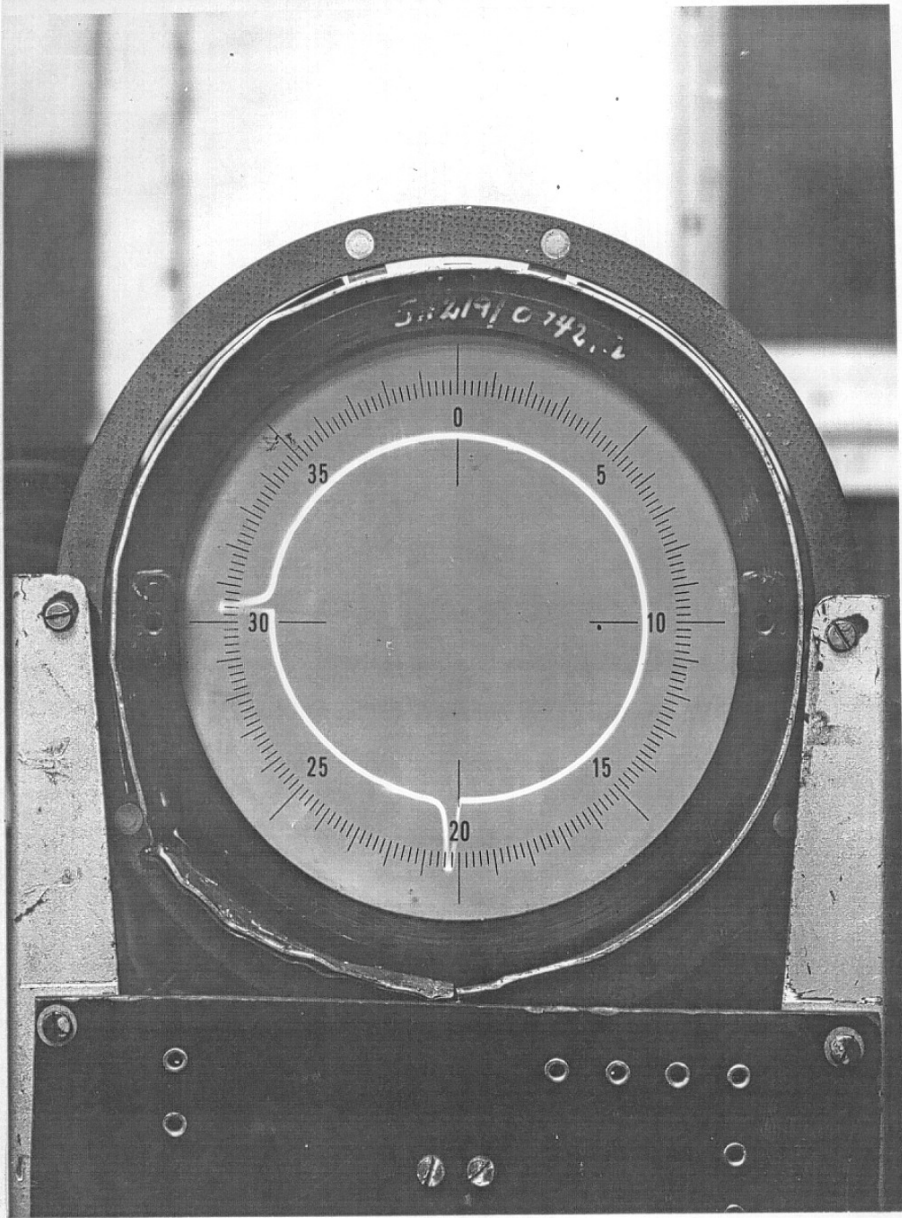

TIME BASE WITH ARTIFICIAL ECHOES. FIG.7

GERMAN GROUND RADAR EQUIPT.
APPARATUS FUSE 62 (WÜRZBERG)
DISPLAY UNIT O S Z. 62.

APZ-1
10-49

TIME BASE GENERATOR

TONE GENERATOR

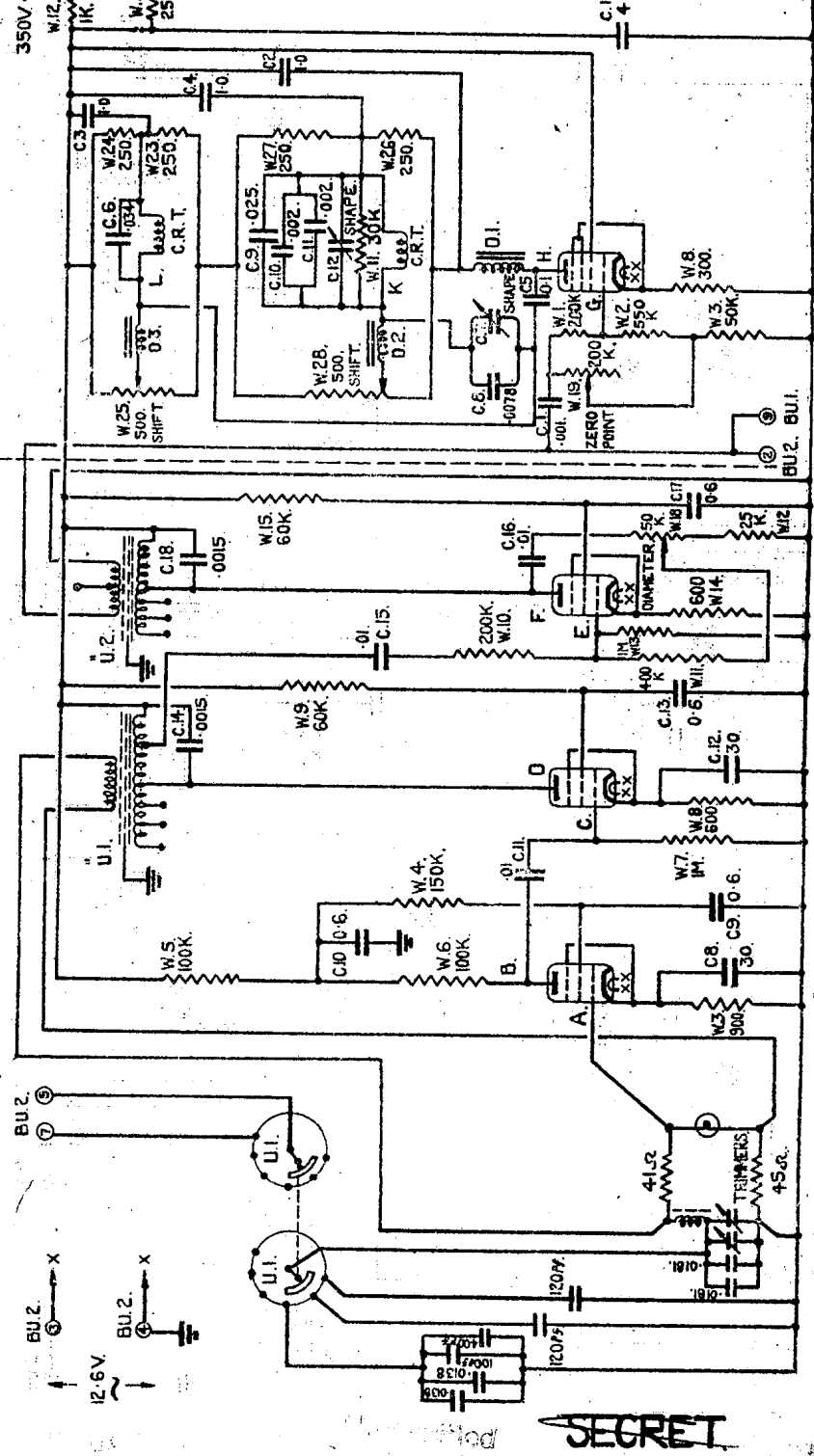

SECRET

TITLE:-

GERMAN GROUND RADAR EQUIPMENT. APPARATUS BU.5E

R.A.M. 210-43
H.
PP. 2002
23.10.58

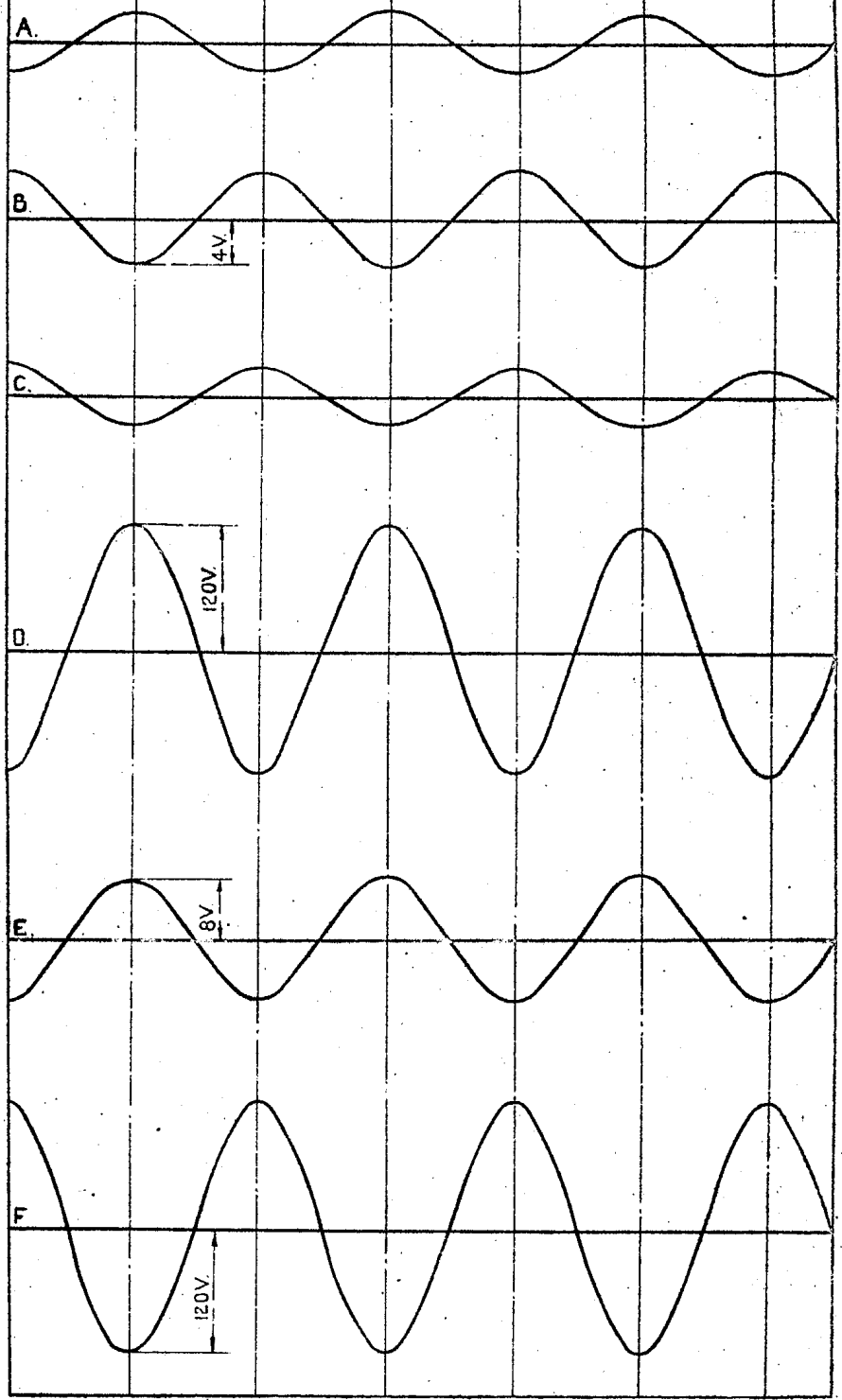

Unclassified ~~SECRET~~

TITLE:-

23.10.43

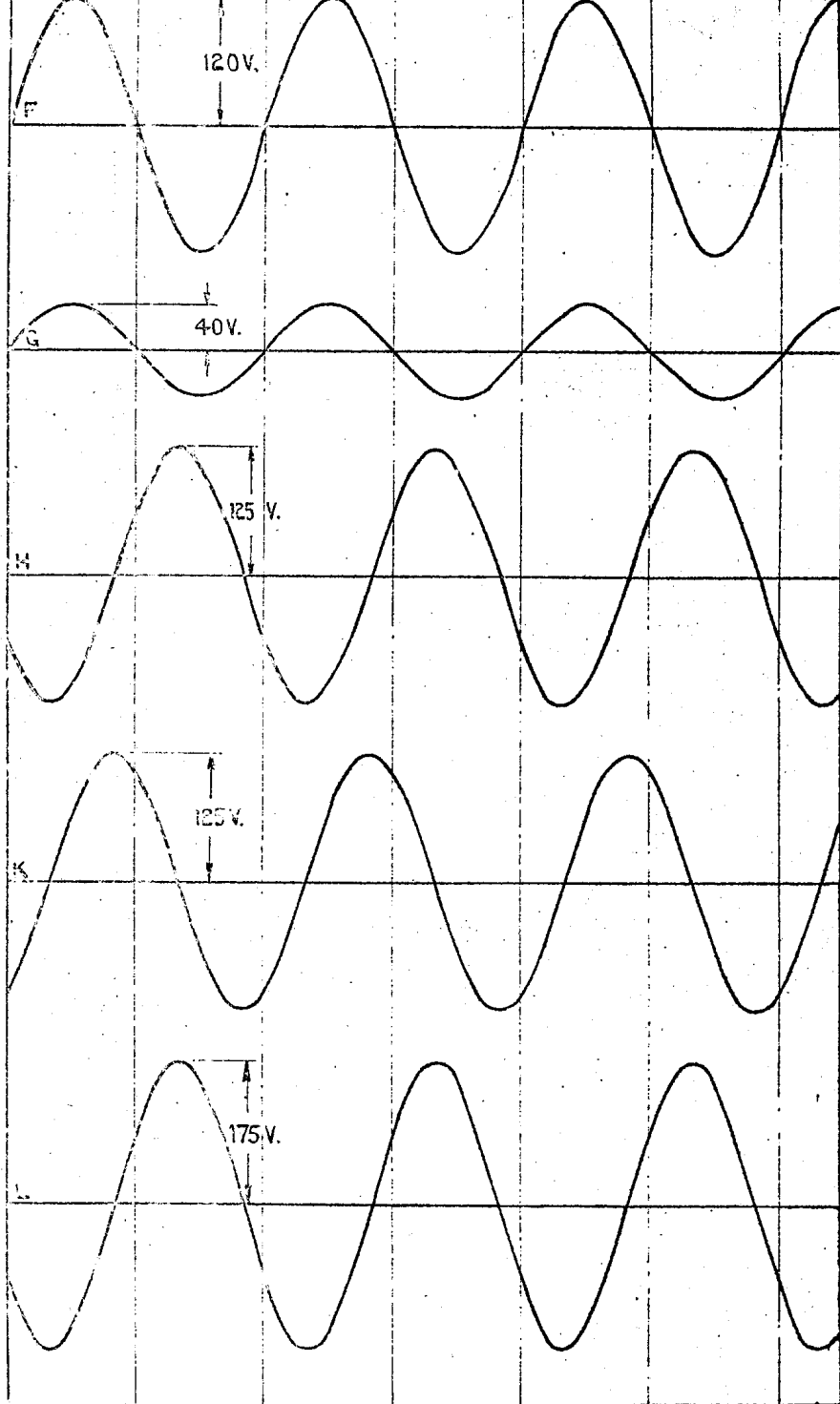

TITLE:-

GERMAN GROUND RADAR EQUIPT
APPARATUS FUSE 62. (WÜRZBURG)
DISPLAY UNIT OSZ 62.
WAVE FORMING IN TIME-BASE GENERATOR

DR. M. Weirig
 TR. CH. 456
 APP. 11.11.43

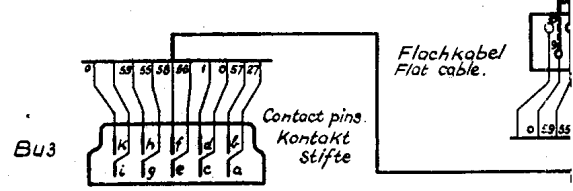
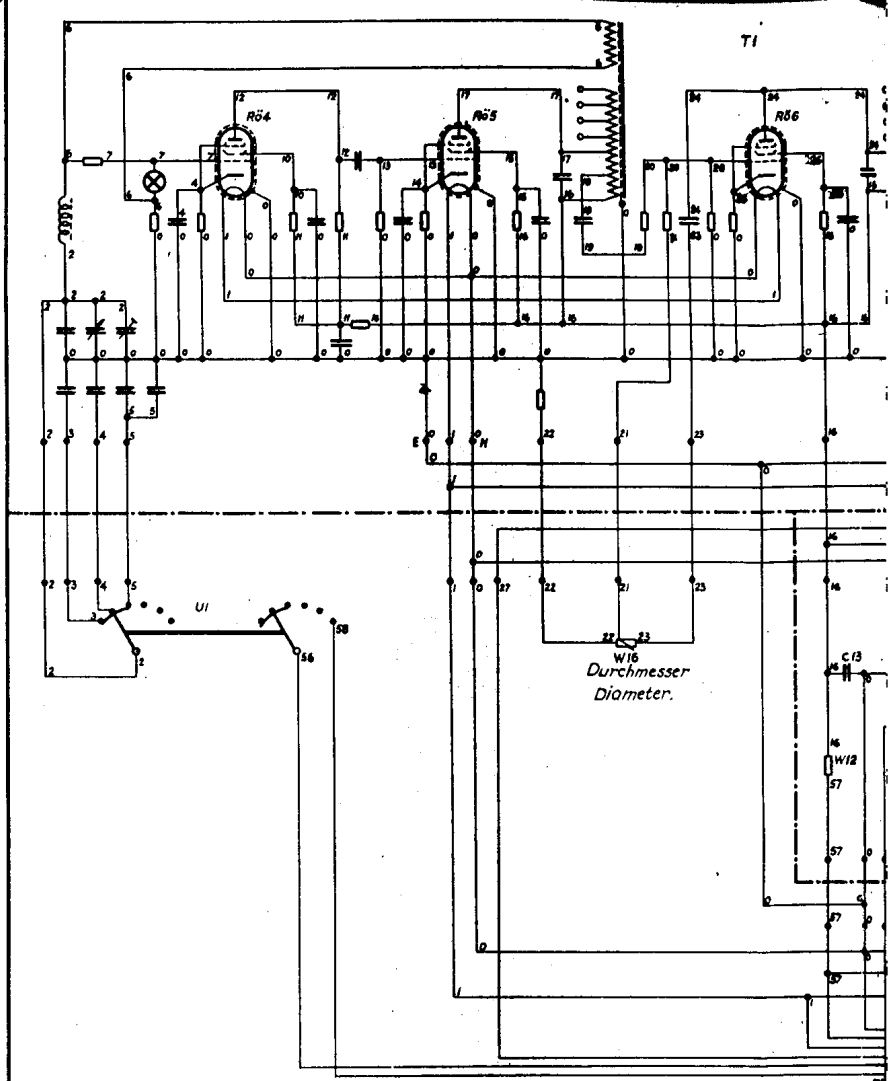

TITLE :-

CIRCUIT DIAGRAM OF THE TONE -
 AND OF THE RANGE MEASURING E
 SCHALTBIKD DES TONGENERATORS
 UND DER ENTFERNUNGS - MEBE

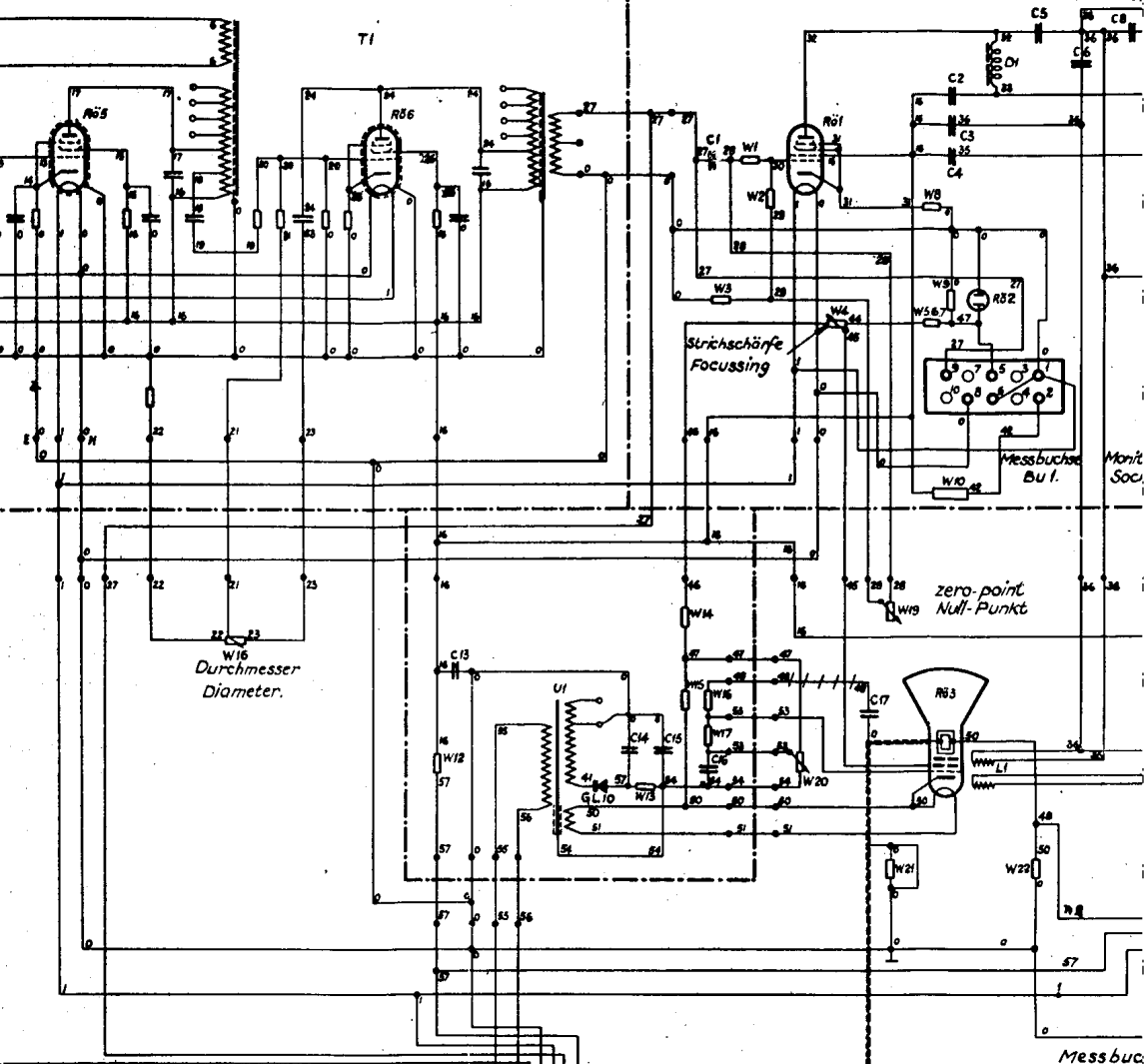

W16
Durchmesser
Diameter.

Strichschärfe
Focussing

zero point
Null-Punkt

Flech kabel
Flat cable.

Contact pins.
Kontakt
stifte

- 1.....+350V
- 2.....Tonregu.z TG 62 Tone generator TG 62
- 3.....12.6 V~
- 4.....
- 5+7.....Relais, Relay
- 6+8.....180V~
- 9.....Zusatzgerat Additional apparatus

(Zeichnung /
Drawing No.

CIRCUIT DIAGRAM OF THE TONE - GENERATOR
AND OF THE RANGE MEASURING EQUIPMENT.
SCHALTBILD DES TONGENERATORS
UND DER ENTFERNUNGS - MEBEINRICHTUNG.

Unclassified
SECRET

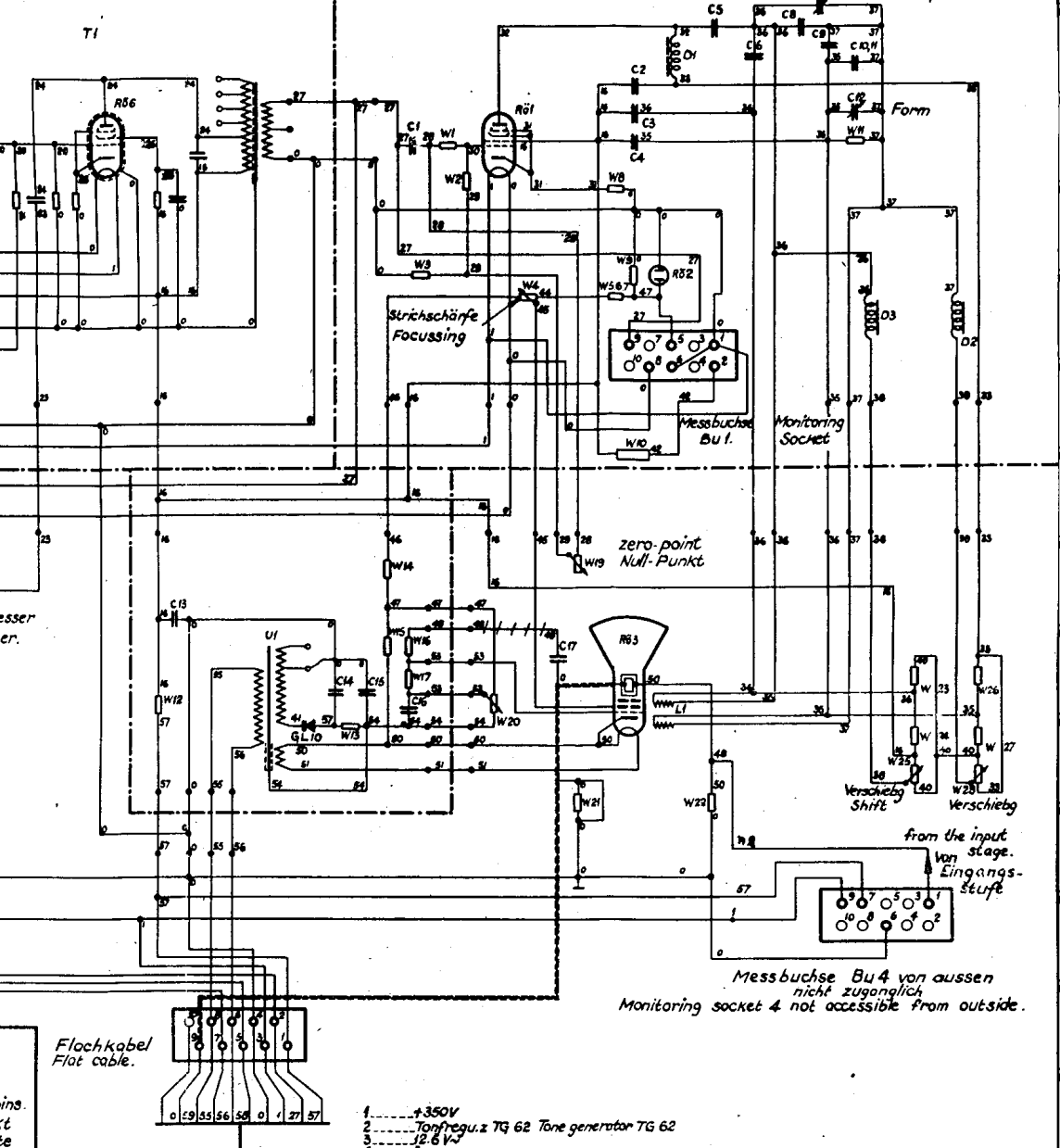

Flachkabel
Flat cable.

- 1 +350V
- 2 Tonfrequ. z TG 62 Tone generator TG 62
- 3 12.6 V
- 4 -
- 5+7 Relais, Relay
- 6+8 180 V
- 9 Zusatzgerat Additional apparatus

Messbuchse Bu.4 von aussen
nicht zuganglich
Monitoring socket 4 not accessible from outside.

(Zeichnung Nr. L 9208)
(Drawing N° L 9208)

Zeichnung 12
Drawing 12

OF THE TONE - GENERATOR
ANGE MEASURING EQUIPMENT.
TONGENERATORS
ERNUNGS - MEBEINRICHTUNG.

Unclassified
SECRET

APPL. 88

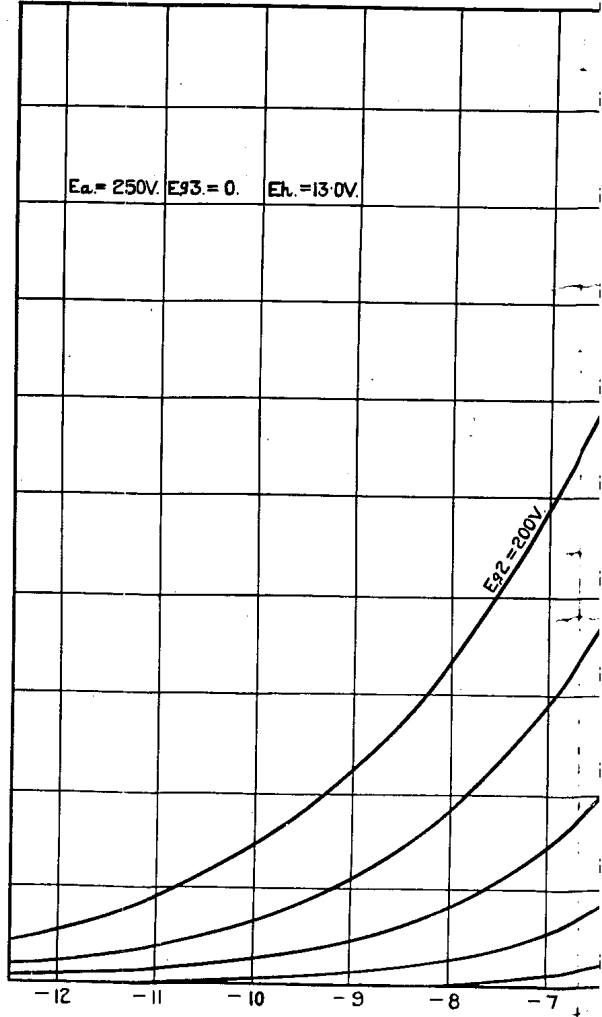

ISSUE No 1.
DATE: - 26-11-43
CHANGES.

GERMAN GROUND RADAR EQUIPMENT
DISPLAY UNIT OS.Z262.
TELEFUNKEN VALVE RY

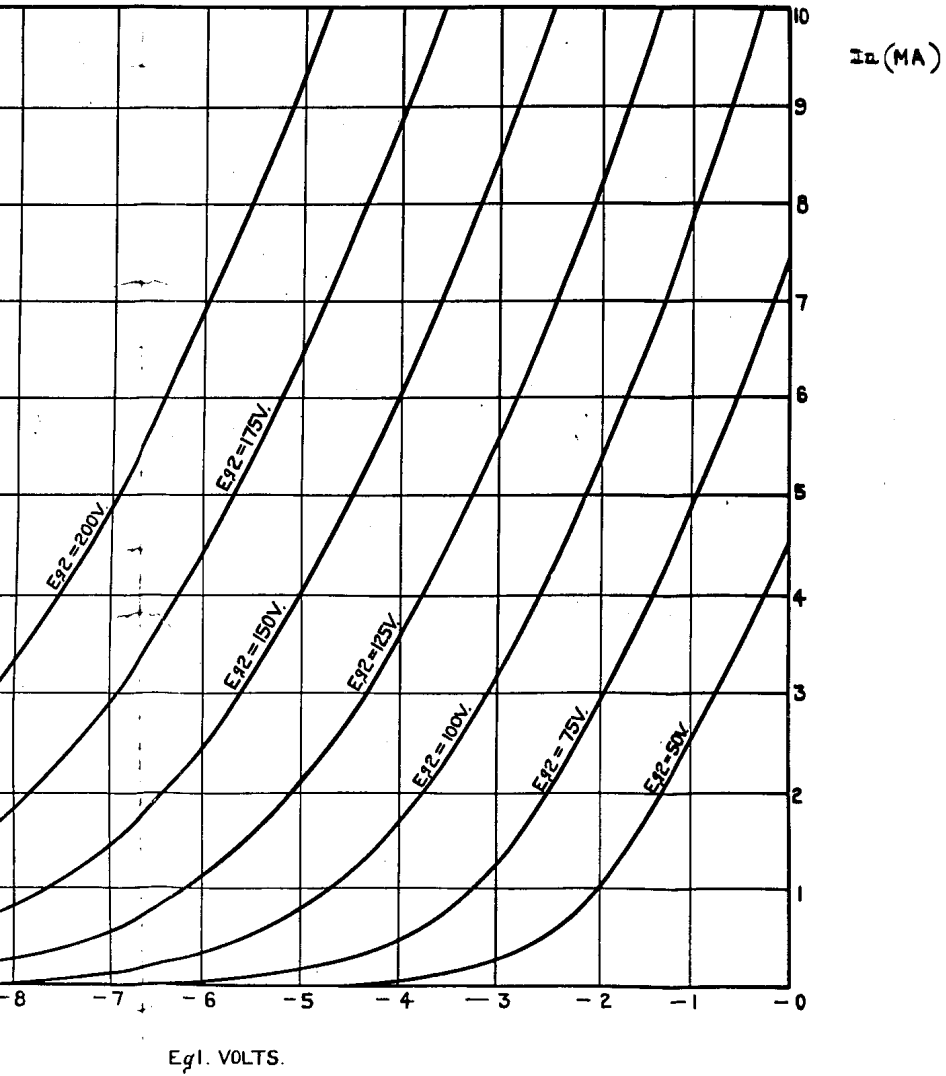

E_{g1} . VOLTS.

... AND RADAR EQUIPMENT. APPARATUS FUSE 62. (WÜRZBURG)
 ... IT OS.Z262.
 ... N VALVE RV.12P. 2000.

DIAG. N° 9279B.